



# SJ30 ARJE

## ELECTRIC ARTICULATING BOOM

### STANDARD FEATURES

- Rotating jib
- Direct AC electric drive
- Dual spring applied, electromagnetically released brakes
- Regenerative braking
- Speed and angle sensing traction control
- 48V 305 Ah battery pack
- 12.5 m/s wind rating
- DC Powered emergency lowering
- Secondary guarding electrical (SGE)
- Drivable at full height
- 355° Non-continuous turret rotation
- 35% gradeability
- Swing out battery trays
- Swing out cowlings
- Modular platform railing system
- Rear-entry sliding mid rail
- Wiring for AC outlet on platform
- Direction sensing drive and steer controls
- Proportional drive and boom controls
- Function speed selector
- Relay based control system
- Colour coded and numbered wiring
- Hour meter
- Operator horn
- Tie down/lifting lugs
- 22 x 7 x 12 solid rubber, non-marking tyres

### ACCESSORIES AND OPTIONS

- Pipe rack
- Tool caddy
- Platform work lights
- Flashing light
- All motion audible alarm
- 1/2" Airline to platform
- Control box cover
- 360 Ah batteries
- 330 Ah AGM batteries
- Rear gate
- Bio oil

Preliminary specifications at time of printing. Consult your local area sales representative for details.

† Standard lead times may be increased when optional equipment is added, consult factory.

‡ Capacities, and machine weights may differ when options are added.

# SJ30 ARJE ELECTRIC ARTICULATING BOOM

Dimensions	SJ30 ARJE
Work Height	11.00 m
Platform Height	9.00 m
Horizontal Reach	6.25 m
Up and Over Height	3.99 m
<b>A</b> Platform Size	0.76 m x 1.17 m
<b>B</b> Stowed Width	1.19 m
<b>C</b> Tailswing	0
<b>D</b> Stowed Height	2.01 m
<b>E</b> Transport Height	2.54 m
<b>F</b> Stowed Length	5.44 m
<b>G</b> Transport Length	4.09 m
<b>H</b> Wheelbase	1.65 m
Ground Clearance	10.16 cm

Specifications	SJ30 ARJE
Turret Rotation	355° NC
Platform Rotation	180°
Jib Length	1.25 m
Jib Range of Motion - Horizontal	180°
Jib Range of Motion - Vertical	142° (+77°/-65°)
Weight	5,750 kg
Gradeability - Counterweight Facing Up	35%
Gradeability - Counterweight Facing Down	25%
Turning Radius (Inside)	1.52 m
Turning Radius (Outside)	3.23 m
Drive Speed (Stowed)	4.8 km/h
Drive Speed (Elevated/Extended)	0.64 km/h
Capacity	227 kg
Local Floor Load (With Rated Load)	1,505 kPa
Overall Floor Load (With Rated Load)	22 kPa
Maximum # of Persons (indoors/outdoors)	2/1
Wind Rating	12.5 m/s
Tyre Type	Solid, N/M
Tyre Size	22 x 7 x 12

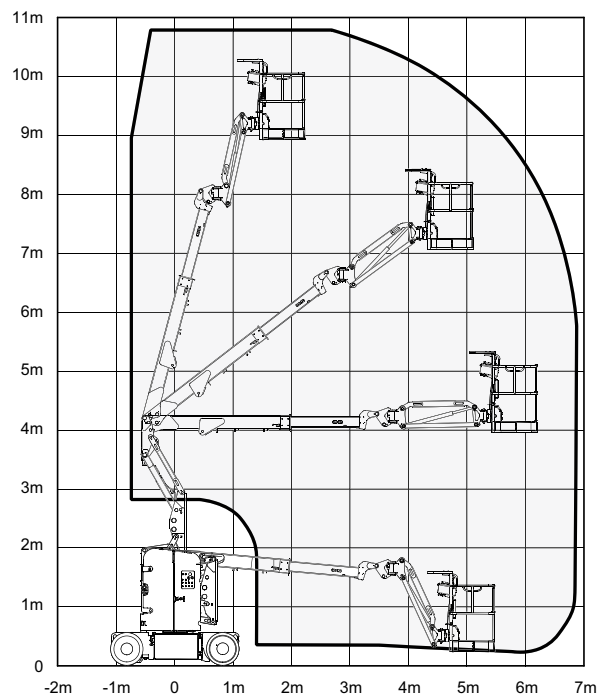
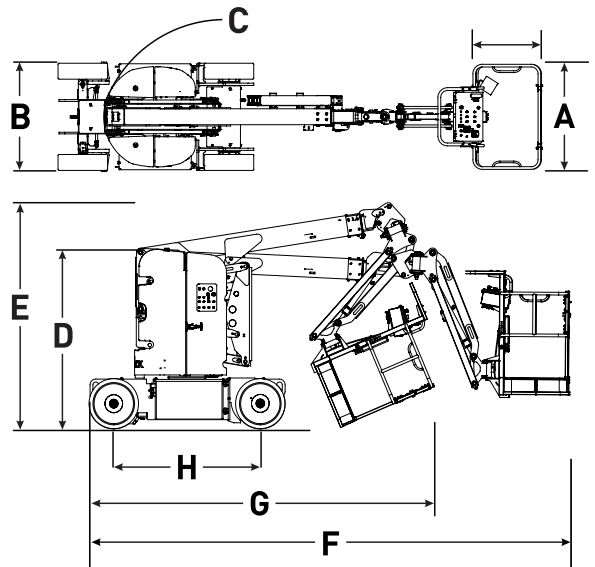

**Skyjack UK**  
 Unit 1, Maes-y-Clawdd  
 Maesbury Road Industrial Estate  
 Oswestry, Shropshire, SY10 8NN  
 Tel: +44 (0) 1691 676235  
 Fax: +44 (0) 1691 676239  
 Email: info@skyjackeurope.co.uk

**Skyjack France**  
 74 Rue Sibert  
 F-42400 Saint-Chamond  
 France  
 Tel: +33 (0) 4 78 73 53 32  
 Fax: +33 (0) 4 78 56 52 42

**Skyjack Germany**  
 Därmannsbusch 2a  
 D-58456 Witten  
 Germany  
 Tel: +49 (0) 2302 20 26 909  
 Fax: +49 (0) 2302 20 25 671

**Skyjack AB Sweden**  
 Agnesbergsvägen 28  
 424 38 Agnesberg  
 Sweden  
 Tel: +46 (0) 31 21 22 45  
 Fax: +46 (0) 31 787 65 10

[www.skyjack.com](http://www.skyjack.com)